

Enseignes et afficheurs à LED

Séquenceur à compteur



Dr. Yves Tiecoura

Séquenceur à compteur



Dr. Yves Tiecoura

Séquenceur à compteur



- Animation d'une enseigne
- Compteur binaire
- Logique de décodage des séquences
- Mémoire morte (ROM)
- Réalisation complète

Une enseigne attrayante

- Qu'est-ce qui fait qu'une enseigne à LED attire l'œil ?
- Sa forme, les couleurs des LED
- Mais surtout les animations !

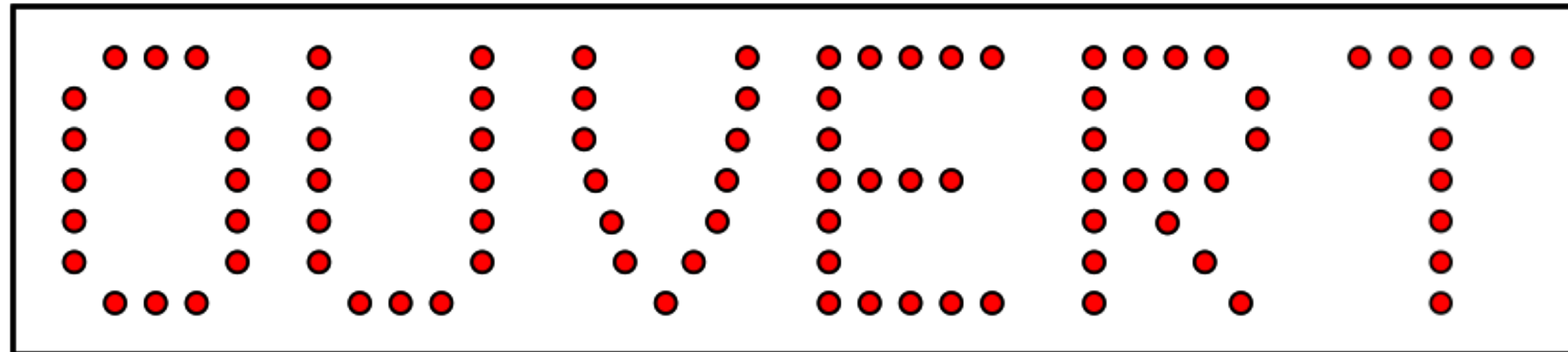

Compteur par 8

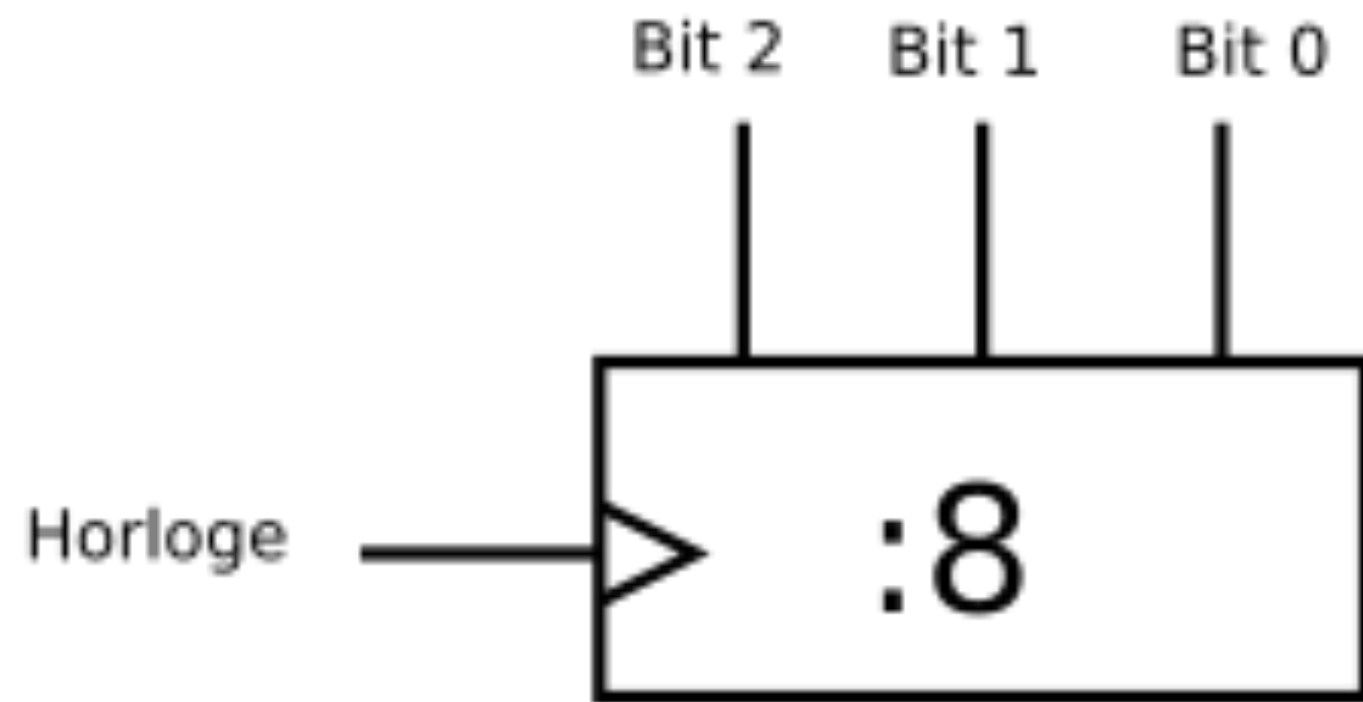

- Diagramme des temps :

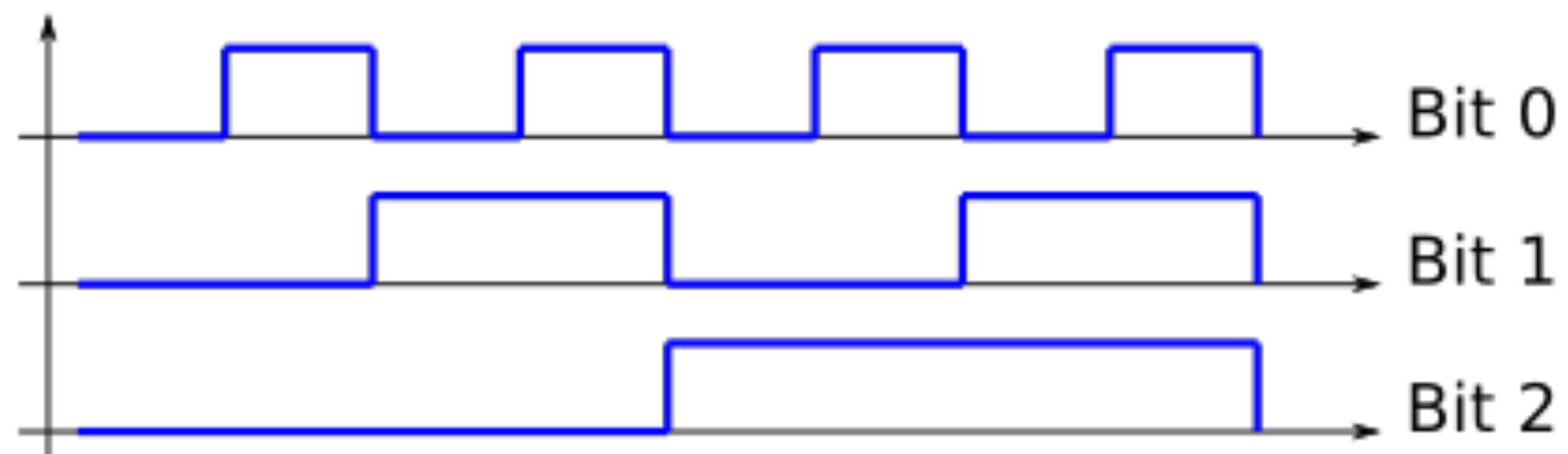

- Graphe d'états :

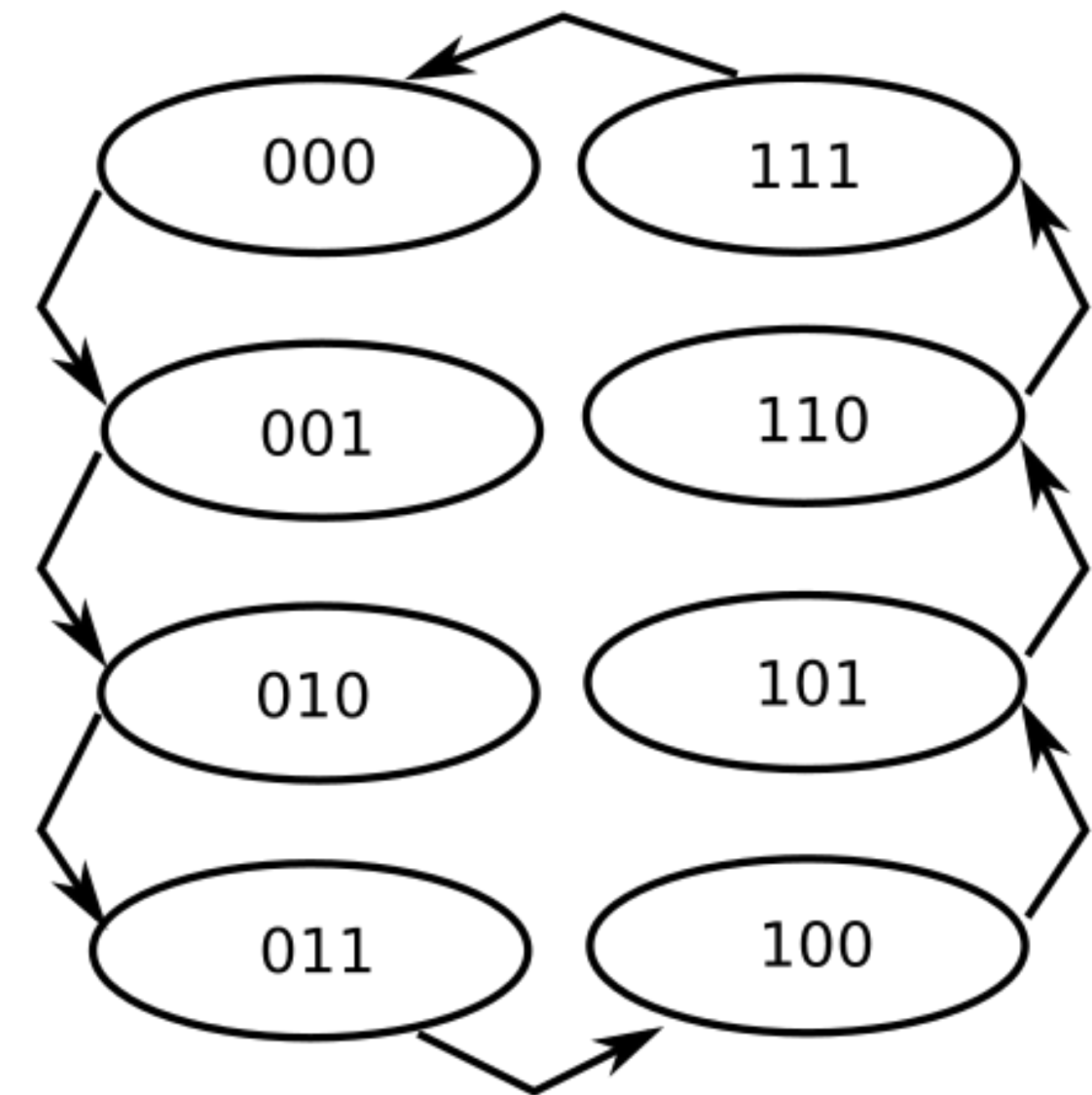

Compteur binaire

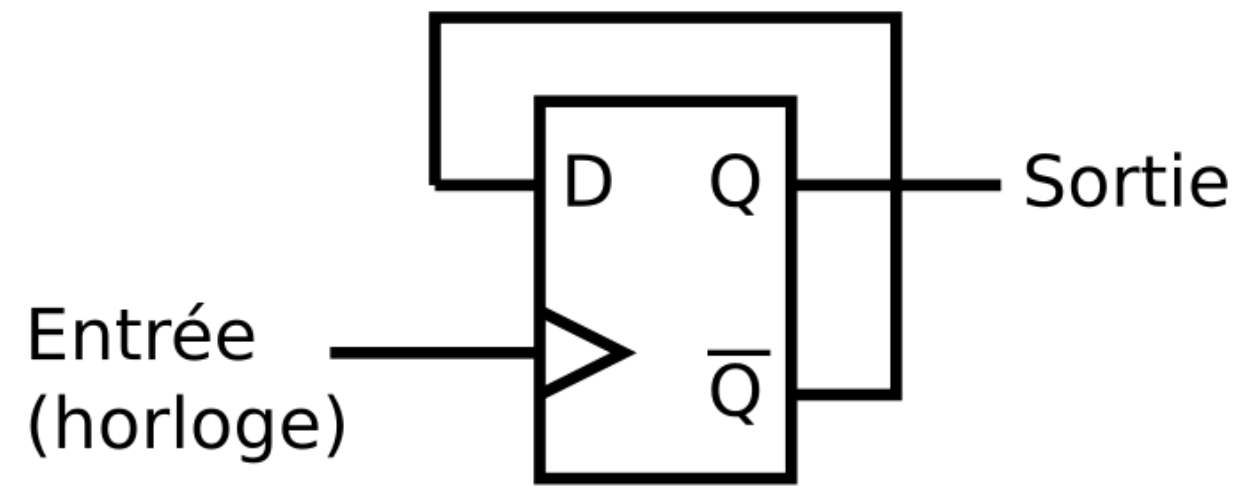

$$\left. \begin{array}{l} Q^+ = D \\ D = \bar{Q} \end{array} \right\} \Rightarrow Q^+ = \bar{Q}$$

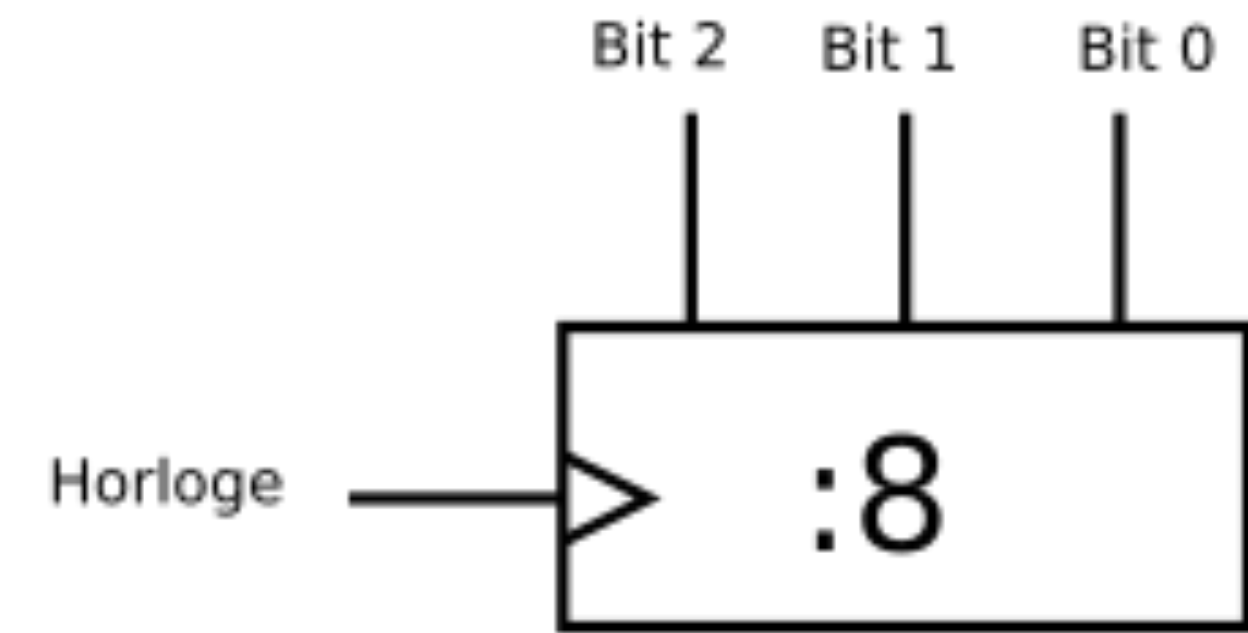
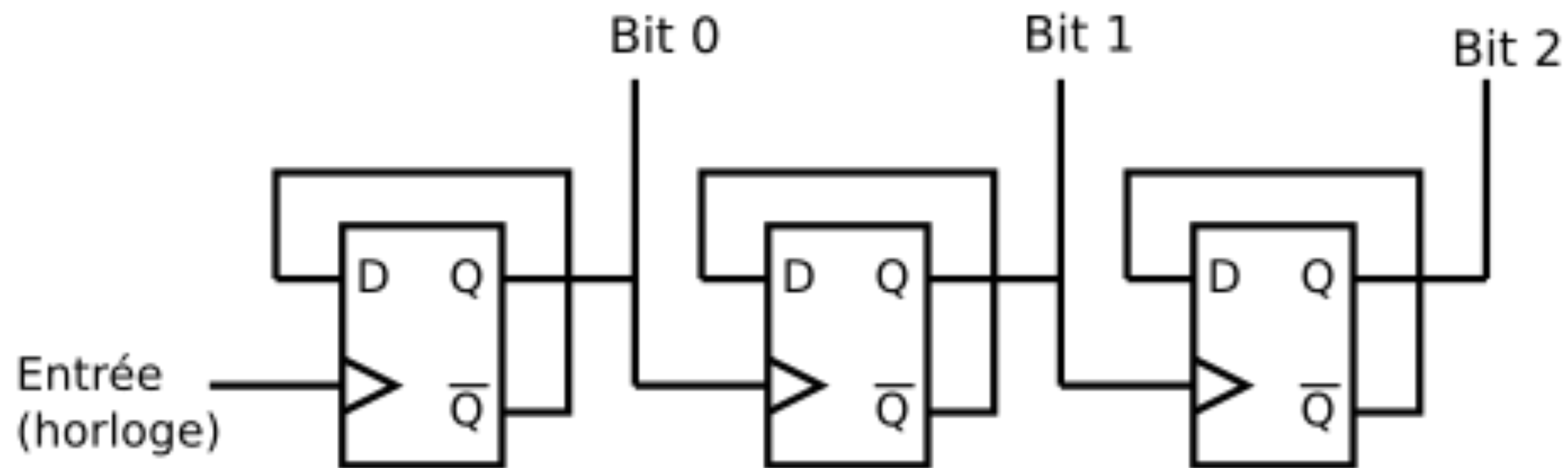
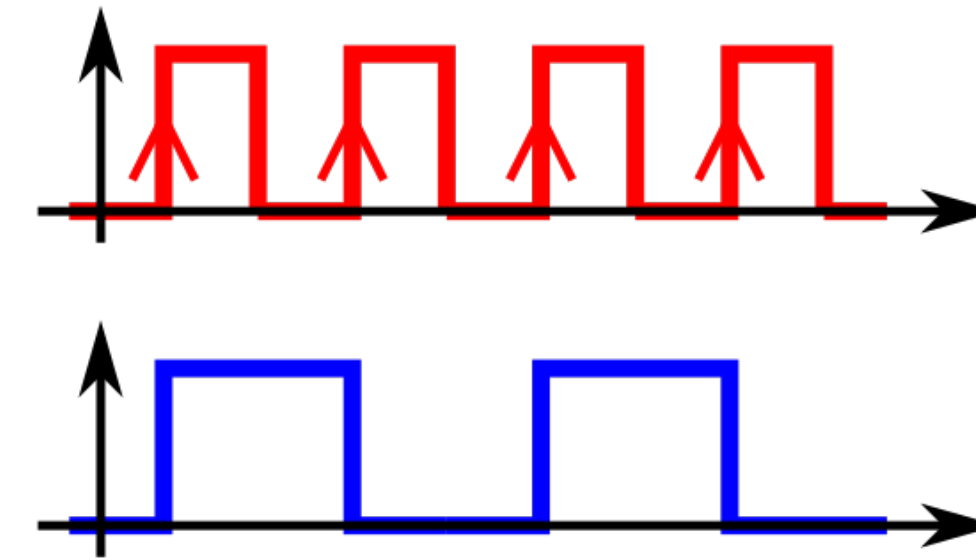

Séquenceur binaire

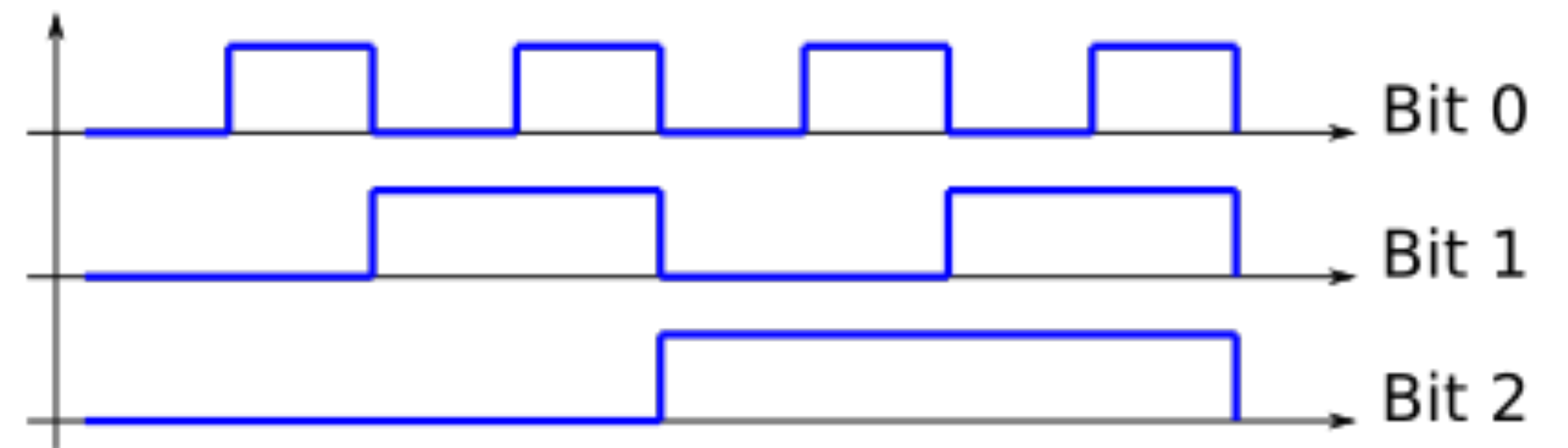
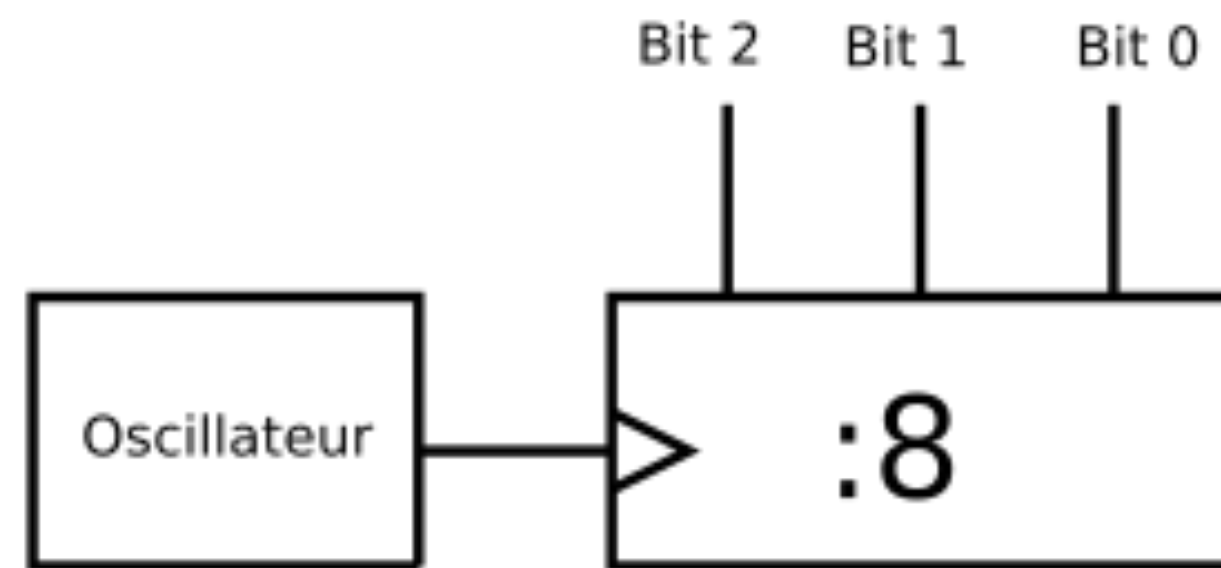

Séquenceur complet

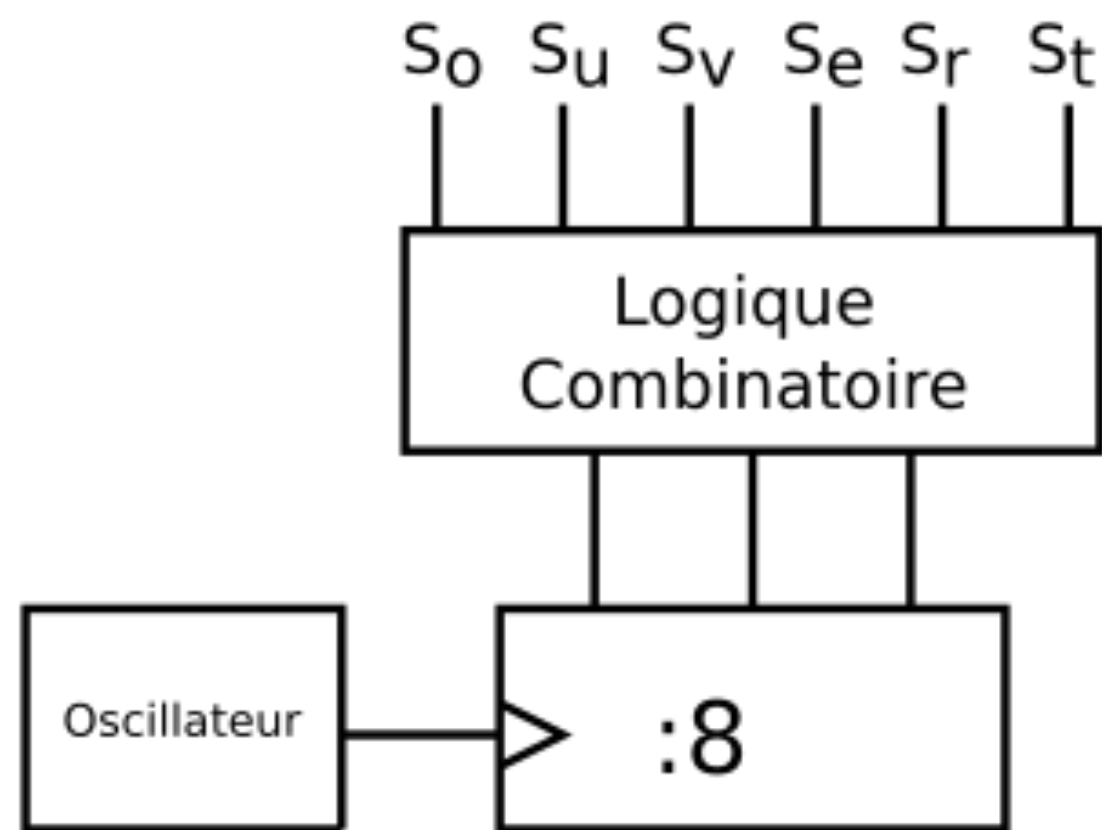
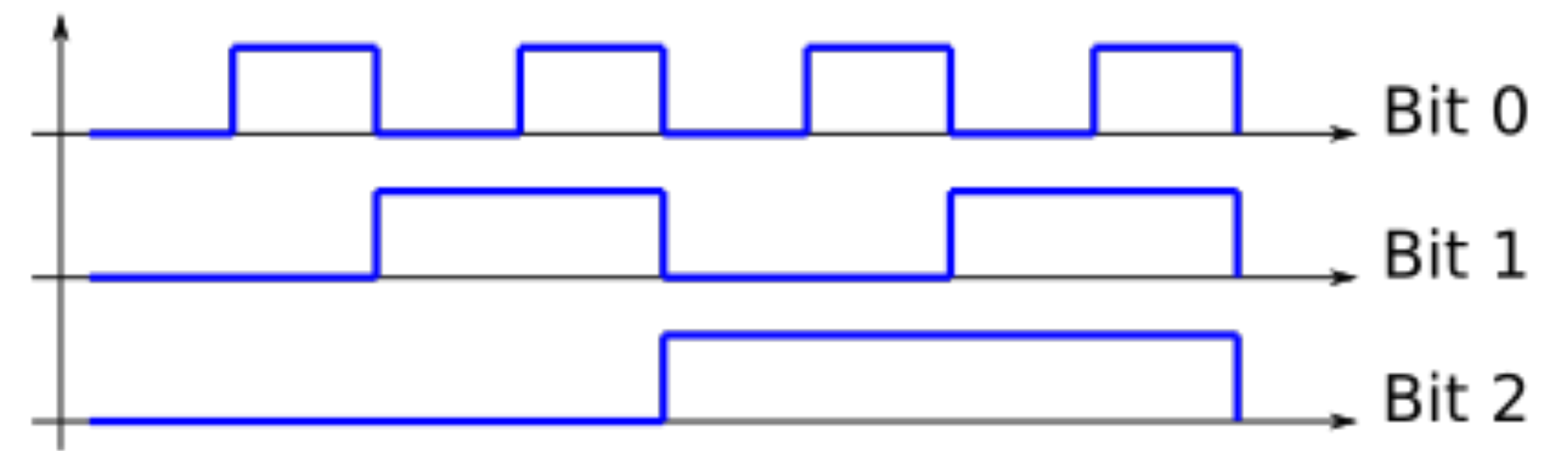
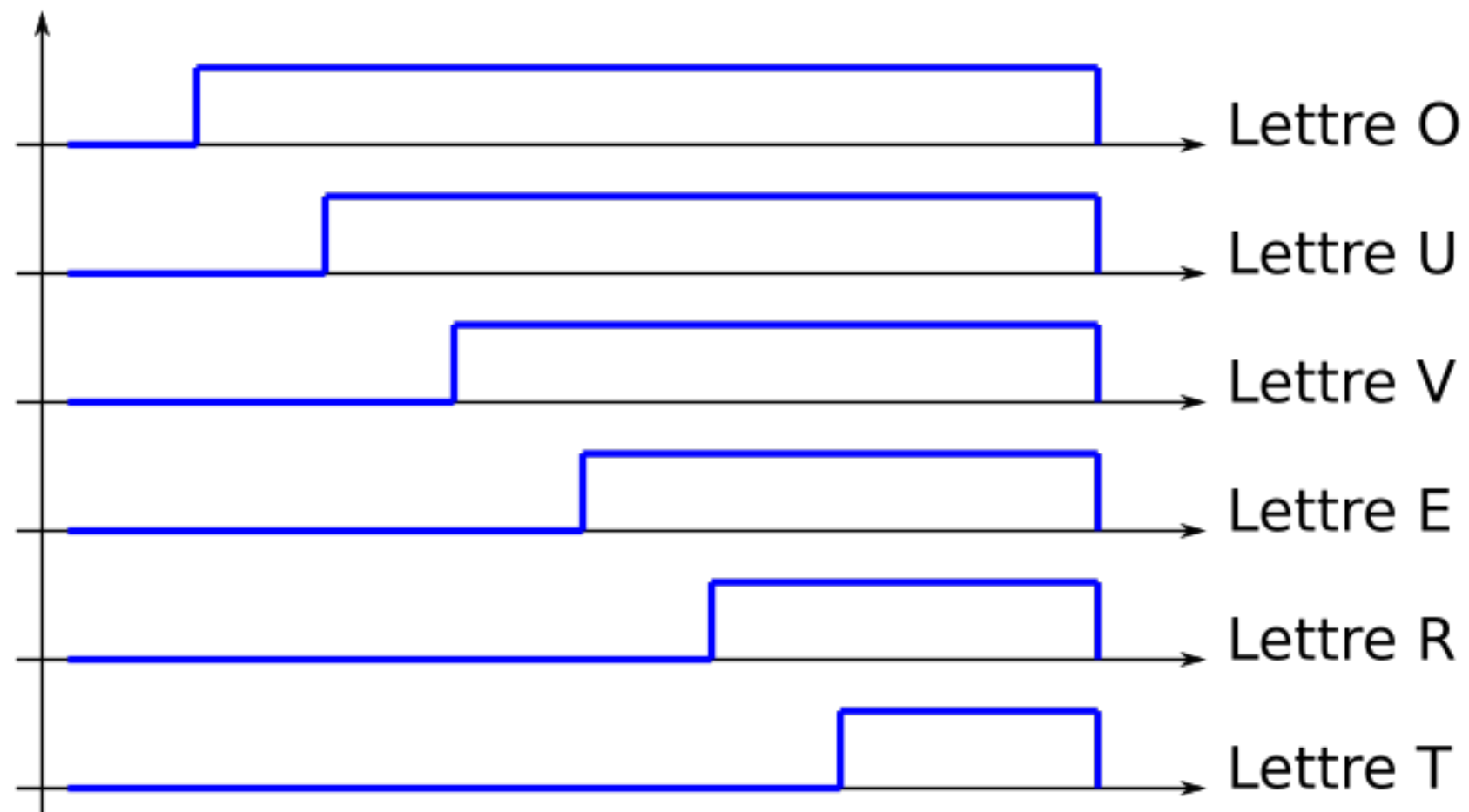

A	B	C	S_0	S_u	S_v	S_e	S_r	S_t
0	0	0	0	0	0	0	0	0
0	0	1	1	0	0	0	0	0
0	1	0	1	1	0	0	0	0
0	1	1	1	1	1	0	0	0
1	0	0	1	1	1	1	0	0
1	0	1	1	1	1	1	1	0
1	1	0	1	1	1	1	1	1
1	1	1	1	1	1	1	1	1

Séquenceur complet



A	B	C	S ₀	S _u	S _v	S _e	S _r	S _t
0	0	0	0	0	0	0	0	0
0	0	1	1	0	0	0	0	0
0	1	0	1	1	0	0	0	0
0	1	1	1	1	1	0	0	0
1	0	0	1	1	1	1	0	0
1	0	1	1	1	1	1	1	0
1	1	0	1	1	1	1	1	1
1	1	1	1	1	1	1	1	1

Mémoire morte comme système combinatoire

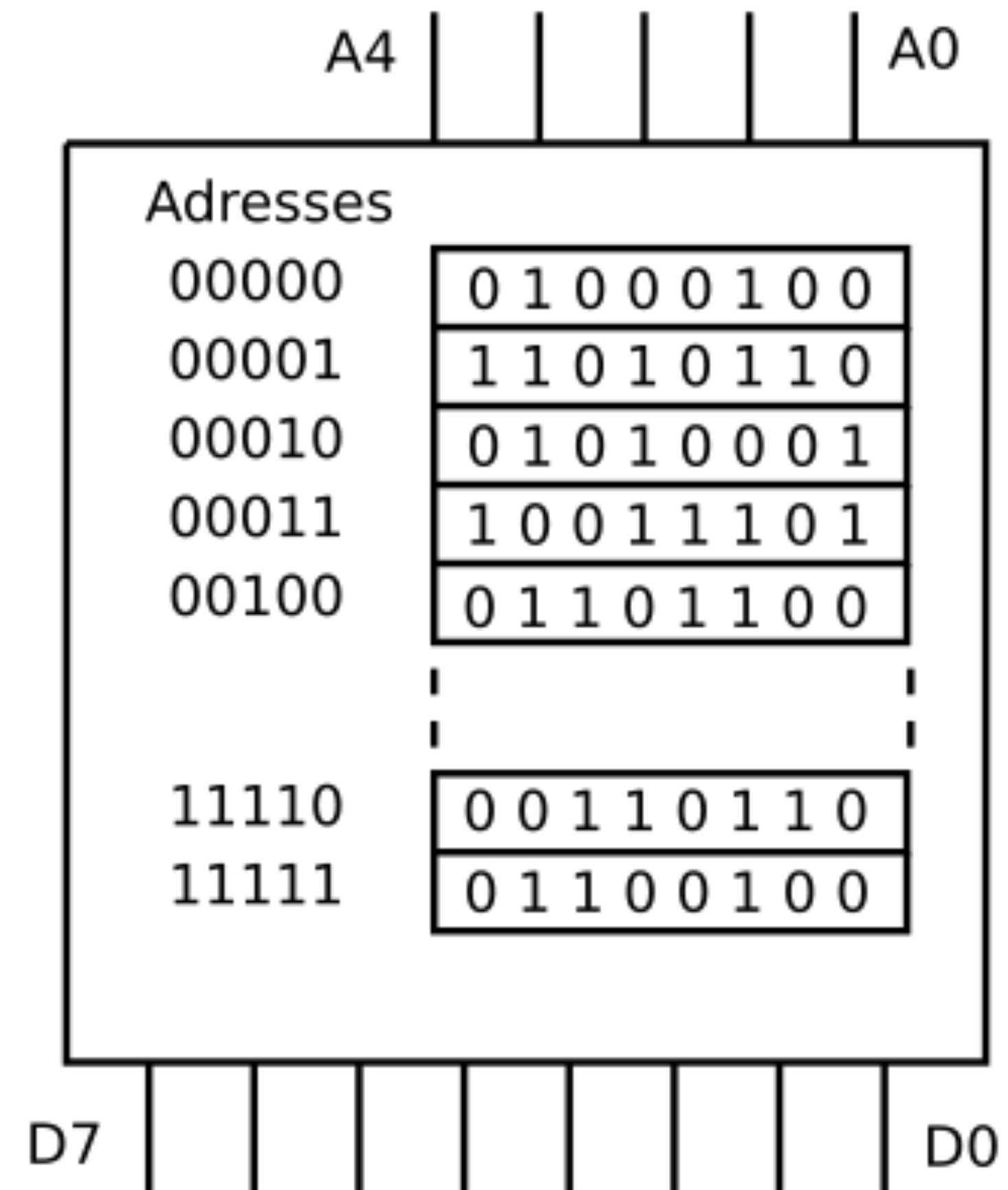
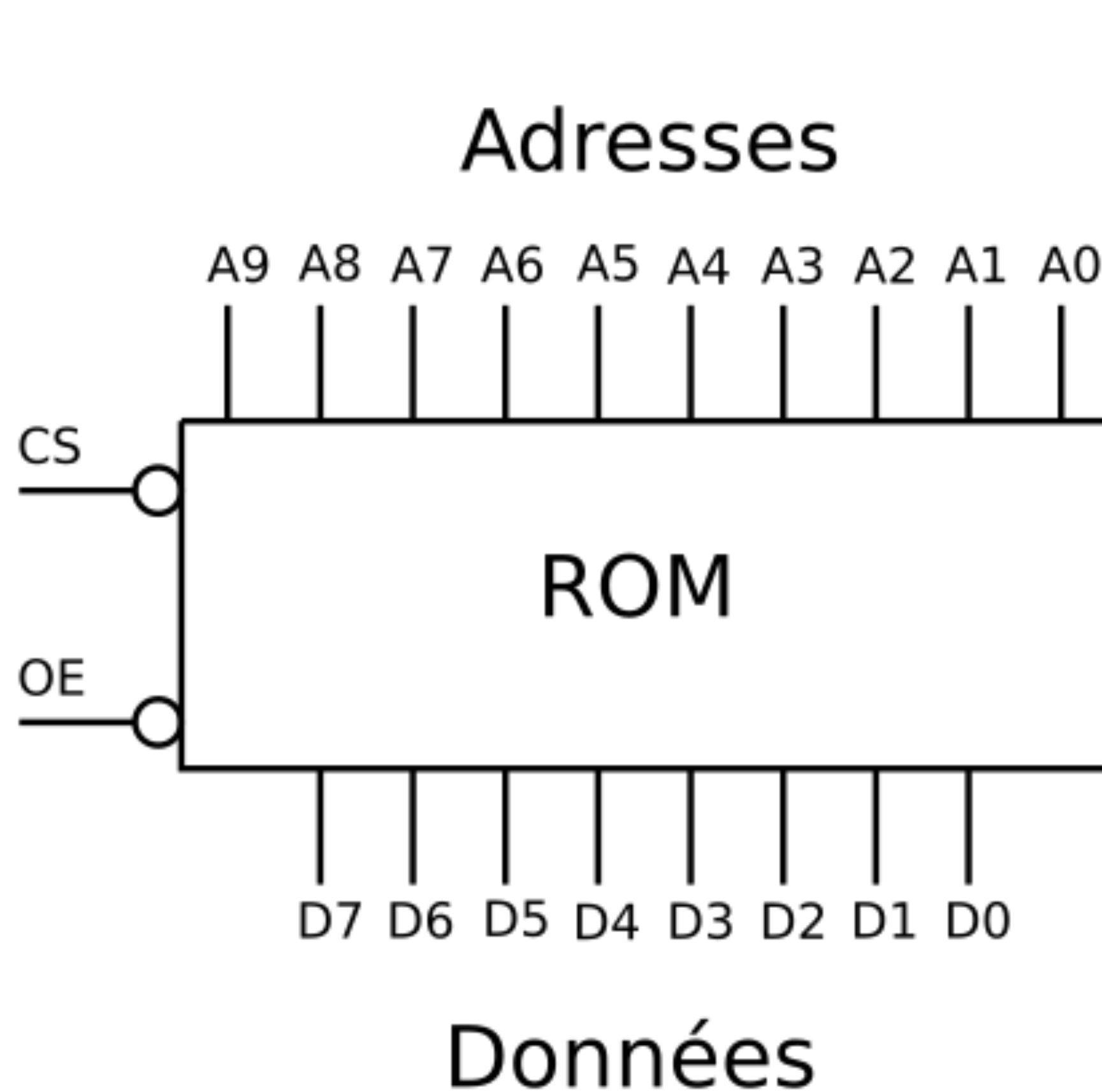

Séquenceur à compteur et ROM

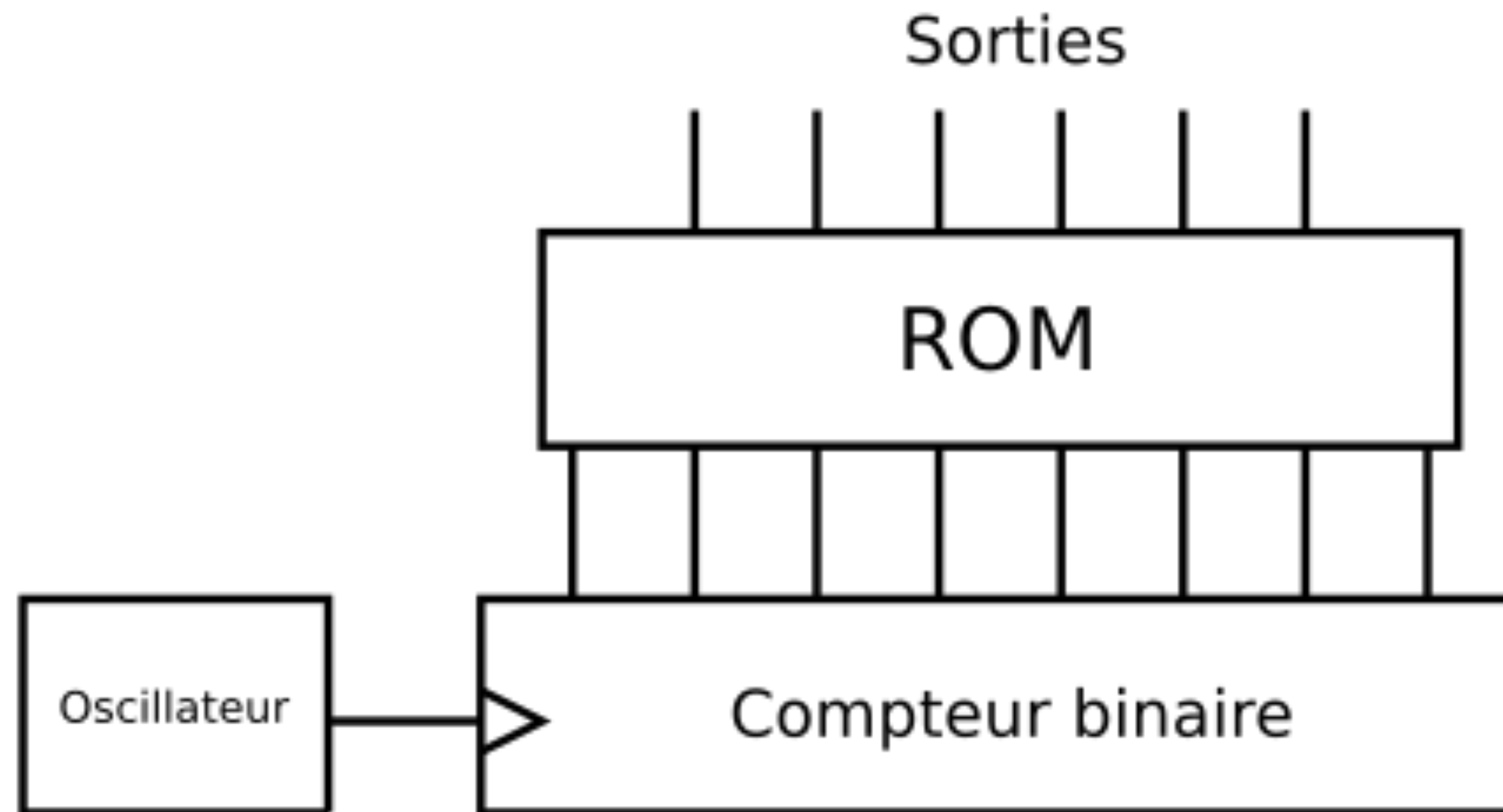

Technologie ROM



- ROM = **Read Only Memory**
- PROM = **Programmable** Read Only Memory
- EPROM = **Erasable** Programmable Read Only Memory



- ROM = **Read Only Memory**
- PROM = **Programmable** Read Only Memory
- EPROM = **Erasable** Programmable Read Only Memory
- EEPROM = **Electrically** Erasable Programmable Read Only Memory



Séquenceur à compteur et ROM

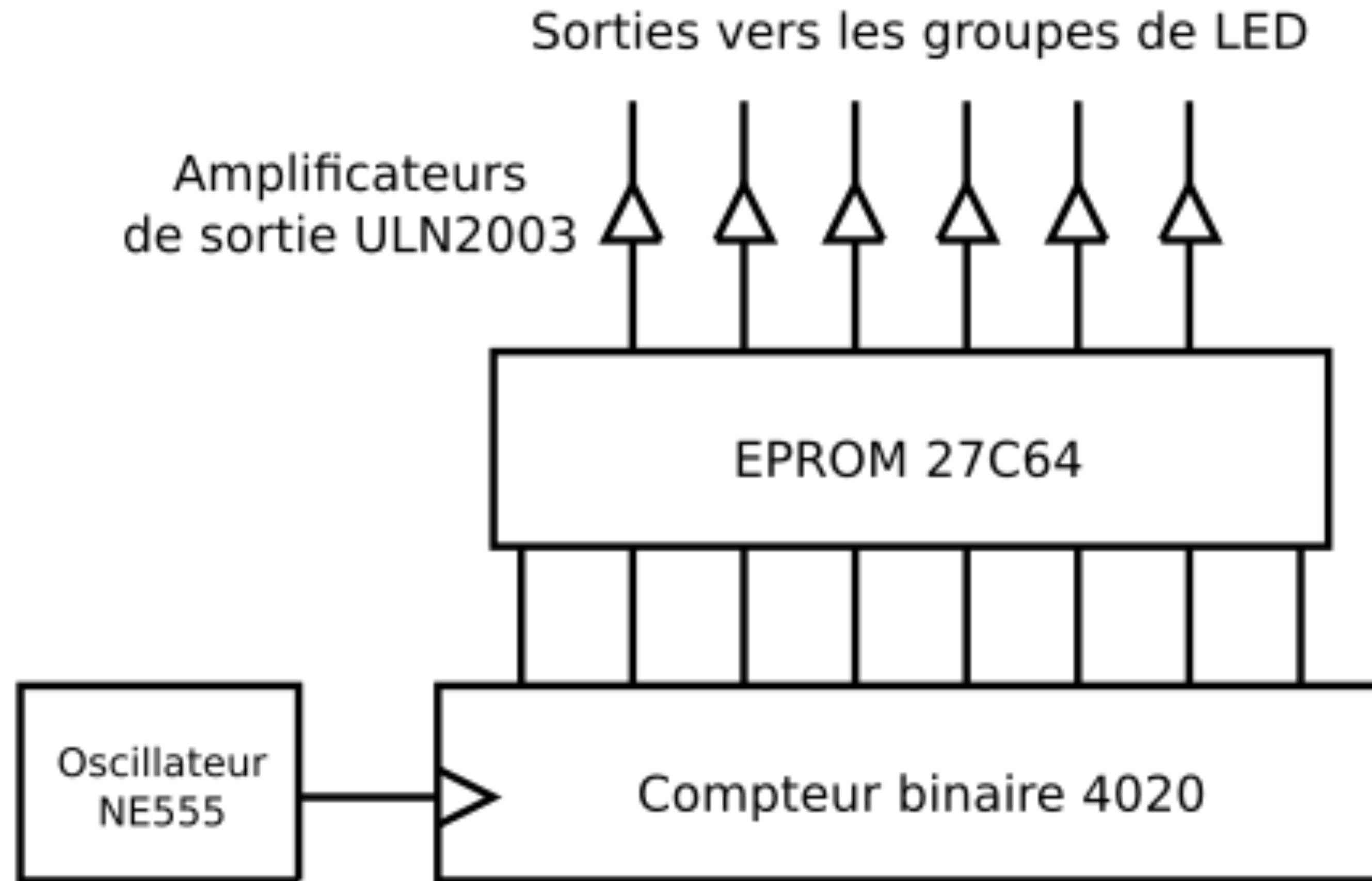

- Microcontrôleur !

Séquenceur à compteur



- Animation d'une enseigne
- Compteur binaire
- Logique de décodage des séquences
- Mémoire morte (ROM)
- Réalisation complète